

**6th Meeting of the Network of
WHO Collaborating Centres for
Occupational Health, Iguassu
Falls, Brazil,
21 –23 February 2003**

**Thebe A Pule,
OCH /WHO/AFRO**

Division of Healthy Environments & Sustainable Development(DES)

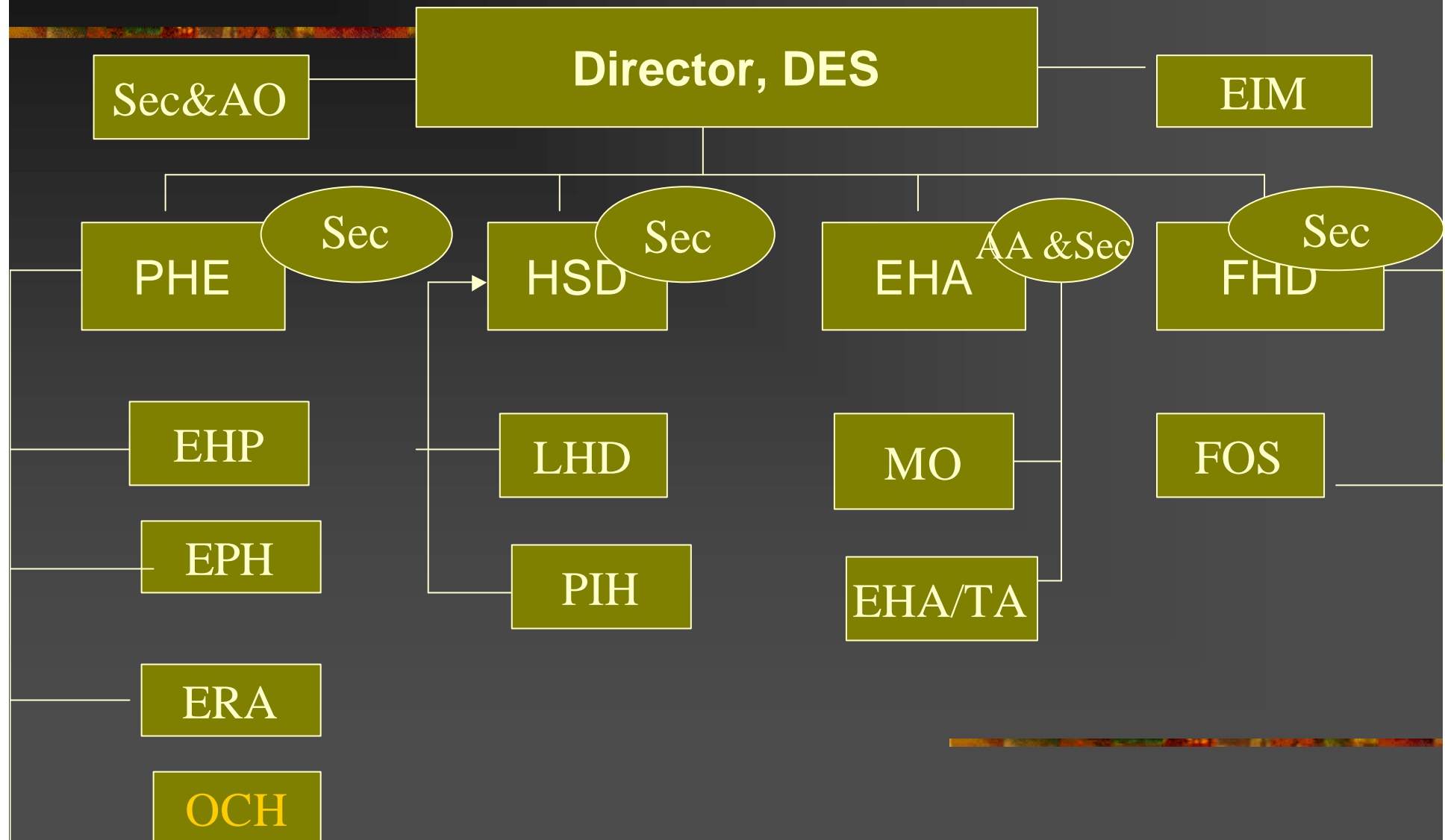

PHE Objective;

- **To facilitate the incorporation of effective health dimensions into regional and national policies impacting on health and environment, and into national development policies and action plans for health and environment, including legal and regulatory frameworks governing the management of human environment**
-

Expected Results

- Evidence based policy guidance and advocacy for promoting environmental planning and management
- Adequate methodology for prevention and response to chemical incidents and other environmental emergencies
- Support for building capacity to implement national health and environment action plans

Occupational Health Objective

- To support countries efforts to improve and maintain the health of the working population in the Region.
- Specific Objectives
 - Development of human resource;
 - Promotion of OCH in the workplace;
 - Development of coherent strategy for generation & dissemination of information;
 - Development of a network of partnerships for the improvement of workers' health

2004 – 2005 Plan Activities

- 39 Countries chose PHE as area of interest
 - Raising/Increase of Awareness
 - Policy Makers- link sustainable development, poverty, GDB to OCH
 - Public, workers, organizations
 - Policy and legislation
 - Create enabling climate
 - Human Resource Development
 - Institutions of higher learning
 - In-service -
 - OCH Programme setting
 - Integrated planning
 - Community Participation/involvement

Activities and Progress

- **OCH Survey in 2001**
 - **Human resources, financial, activities**
- **Started supporting OCH activities**
 - **Human resource development**
 - **Development of national policies**
 - **Identifying collaborating centres, partners & experts**
 - **Information dissemination**
- **Creating a network of expertise – Collaborating Centres**
- **Initiated the joint effort between WHO & ILO**
 - **WHO/ILO collaboration meetings**
 - **Launching in May 2003**
 - **Joint planning and implementation**
- **Plan – 2004 - 2005**

Areas Identified

Taskforces

- 2: Intensive Partnership in Africa
- 3: Child Labour/Adolescent Workers
- 4: Elimination of Silicosis
- 5: Health Care workers
- 7: Mental health & Stress at Work
- 8: Promotion of OHS in S Enterp & Inf Sect
- 10: Preventive Technologies
- 11: Training Programmes & Modules
- 12: Internet Resources & Network
- 13: National Profiles and Indicators
- 14: Cost-effectiveness of Interventions
- 15: Global Burden of Disease

Network of Expertise and Partnership in Africa

- National Centre of Occupational Health
 - Silicosis
 - Publication
 - Website
 - University of Cape Town*
 - Informal sector
 - University of Benin*
 - Distance Learning
 - International Labour Organization(ILO)
 - ** prospective collaborating centre*
-

WHO/ILO Joint Effort in Occupational Health & Safety in Africa (WHO/ILO AJE)

■ Identified Areas of Collaboration

- Human Resource Development focused on capacity building

- National policies, programmes & legislation

- Information, research & awareness raising; and
(*CIS*)

- Promotion of occupational health & safety in particular hazardous occupations, vulnerable groups (including informal sector workers & children) and in newly transferred technologies

Progress with WHO/ILO AJE

- Two meetings between WHO & ILO HQ
- Two collaboration sensitization meeting
- Meeting between WHO & ILO RA's
- Exchange of progress documents
- Planning meetings in Benin – March 2003
- Planned Launch Meeting in Benin in May 2003?

Constraints & Challenges

- Resources
 - Human Resources
 - Financial
- Fragmentation
 - Labour
 - Health
 - Welfare
- Information Management
- Two Systems
- Research

Resources (2004 –2005)

Budget	Regional	Country	O. Sources
■ '000			
■ 6 419	2 254	3 915	250
■ Human			
■ Regional Advisor			
■ Network of Collaborating Centres; country to country cooperation; experts			

■ Thank you

■ Merci

